



STRONG PISTON/DIAPHRAGM DOSING from 2.2 to 2 x 1.500 l/h

The preferred choice for complex tasks

The Grundfos Alldos DMH range is a series of extremely strong, robust pumps for situations where you need a substantial dosing range and high-pressure capability. The pumps are accurate to within +/- 1 per cent of the rated flow, making the DMH series the preferred choice for complex tasks and automatic process integration. And their strength is a matter of public record: Customers worldwide have enjoyed years of trouble-free operation from their DMH pumps.

Get the pump configuration you need

A number of different product configurations are available to match your requirements. For example, you can choose between electric or pneumatic servomotors, opt for an AC inverter controlled motor, pick special dosing heads with electrical heating, or have your pumps fitted with double diaphragms with failure indication. If in doubt, ask your Grundfos Alldos consultant to help you choose the best configuration for the task.

Prepared for extreme situations

AMS diaphragm protection keeps both the pump and overall application protected against extensive high pressures in the event of blockages in the discharge line. Similarly, pressure relief valves guards the pump against excessive pressure in the system.

Stroke length adjustment ensures precise dosing

Very precise and accurate stroke length adjustment, with setting carried out using a Vernier scale, brings you optimum dosing with a repeatability of only +/-1%.

Enjoy the Teflon effect

The DMH pumps can shrug off almost anything. They are fitted with Teflon diaphragms, and the parts that come into contact with the liquids dosed are available in material combinations to suit virtually all dosing scenarios.

Ready for tough applications

The tough application areas within the oil refinery industry can also benefit from the DMH range: several models have been designed and approved in accordance with API 675.

Technical Specifications

- 1 Motor
- 2 Worm gearing
- 3 Eccentric
- 4 Recuperating spring (some models excluded)
- 5 Sliding plug
- 6 Piston
- 7 Combined overpressure and degassing valve
- 8 Degassing valve
- 9 Diaphragm protection valve (AMS)
- 10 Dosing diaphragm
- 11 Dosing head
- 12 Suction valve
- 13 Pressure valve
- 14 Stroke-length adjusting knob
- 15 Air vent screw with oil-level gauge

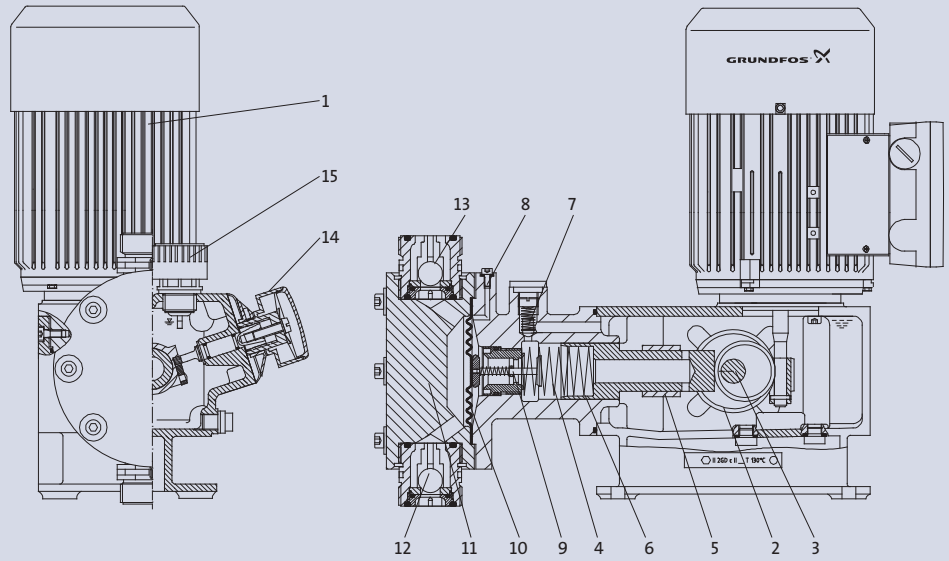

Performance range

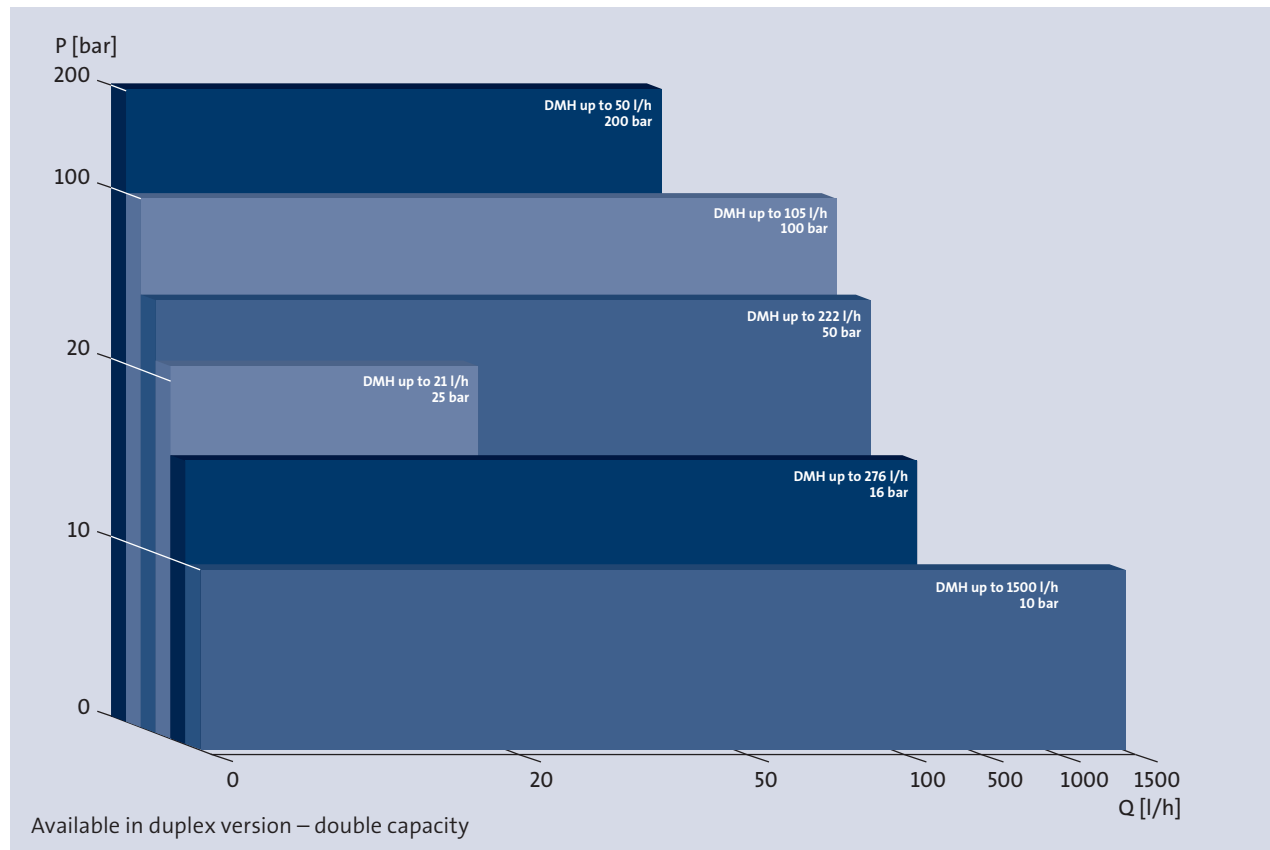

96603949 1205 \ Corporate Branding \ 15933